

# Clarke®



## PARAFFIN/DIESEL HEATER

MODEL NO: XR60

PART NO: 6931002

## OPERATION & MAINTENANCE INSTRUCTIONS

UK  
PA | CE



ORIGINAL INSTRUCTIONS

DL1123 - ISS 7

---

## **INTRODUCTION**

---

Thank you for purchasing this CLARKE product.

Before attempting to use this product, please read this manual thoroughly and follow the instructions carefully.

This is a forced air unit, where a fan pushes the air through the heater body. Proper combustion depends upon this air flow; therefore, the heater must not be modified or operated with parts removed or missing. Likewise, safety systems must not be circumvented or modified in order to operate the heater.

---

## **GUARANTEE**

---

This product is guaranteed against faulty manufacture for a period of 12 months from the date of purchase. Please keep your receipt which will be required as proof of purchase. This guarantee is invalid if the product is found to have been abused or tampered with in any way, or not used for the purpose for which it was intended.

Faulty goods should be returned to their place of purchase, no product can be returned to us without prior permission.

This guarantee does not effect your statutory rights.

---

## **FUNCTION AND OPERATING PARAMETERS**

---

This is a multi-fuel (Diesel or Paraffin), forced air heater. It's intended use is for drying and the warming of commercial/industrial buildings where adequate ventilation is provided.



- It must be operated as prescribed in the operating manual.
- It is not intended to be used for domestic use or for the heating of habitable areas.
- It is not intended to be used to reach and maintain a certain level of human thermal comfort within an enclosed space in which the heater is situated.
- It is not intended to be used in enclosed areas with restricted ventilation.
- It is not for use in areas with high levels of fluctuating drafts.
- The heater must be placed on flat level non combustible surface during operation.
- It is not intended for warming animals or live stock.

---

## SAFETY SYMBOLS

---

The following symbols appear on the heater.

	<b>HOT SURFACE, DO NOT TOUCH</b>		<b>DO NOT COVER</b>
---	----------------------------------	---	---------------------

---

## SAFETY WARNINGS

---



**CAUTION: DUE TO THE HIGH SURFACE AND EXHAUST TEMPERATURES, ADULTS, CHILDREN AND ANIMALS MUST KEEP CLEAR OF THE UNIT TO AVOID BURNS OR CLOTHING IGNITION.**

---

**Your safety is important to you and to others, so please read these instructions before you operate this heater.**

1. Failure to comply with the precautions and instructions provided with this heater can result in death, serious bodily injury and property loss or damage from the hazards of fire, explosion, burns, asphyxiation, carbon monoxide poisoning, and/or electric shock.
2. Only persons who understand and follow the instructions should use or service this heater.
3. When used, the heater should rest on a suitable horizontal and stable insulating material at least 1" thick and extending 3 feet or more beyond the heater in all directions
4. **NOT** for home or recreational vehicle use.
5. **DO NOT** use petrol or other volatile fuels.
6. Disconnect the heater from the power supply before adding fuel.
7. Always re-fuel outdoors away from any open flame or other sources of ignition.
8. **DO NOT** use an external fuel source.
9. **DO NOT** use the heater where flammable liquids or vapours may be present.
10. **DO NOT** start the heater when the combustion chamber is hot.
11. Plug the electrical cable into a properly grounded mains socket.

12. **DO NOT** leave the heater unattended when in use.
13. **DO NOT** start or use the heater if there is unburnt fuel in the combustion chamber.
14. **DO NOT** use if dropped.
15. Check the heater thoroughly for damage. **NEVER** operate a damaged heater.
16. This heater is for indoor use only.
17. **DO NOT** use this heater in the immediate surrounds of a bath, a shower or a swimming pool.
18. **DO NOT** use this heater in small rooms when they are occupied by persons not capable of leaving the room on their own unless constant supervision is provided.
19. Use in well ventilated spaces and provide at least 2 sq. ft. (0.19 sq.m.) of air opening near the floor and 2 sq. ft. (0.19 sq. m.) near the ceiling directly to outdoors. Increase air openings for each additional heater.
20. **ALWAYS** keep combustibles, like textiles, paper and wood at least 8 ft. (2.4 m) from the front of the heater and 3 ft. (1 m) from the top, sides and rear.
21. Locate the heater 10 ft. (3 m) from canvas or plastic coverings and secure them to prevent movement.
22. Make sure that the heater is not directly exposed to rain or water spray.
23. **NEVER** use in living spaces and/or where children may be present.
24. **DO NOT** use with ductwork. **DO NOT** restrict air inlet or exit.
25. **DO NOT** move or service the heater while hot or in operation.
26. Use only in accordance with local regulations and relevant building codes.
27. This heater is only intended for use in industrial, commercial and building industries, it is **NOT** to be used by children or persons with reduced physical, sensory or mental capabilities, or lack of experience and knowledge.
28. If the supply cable is damaged, it must be replaced by the manufacturer, its service agent, or similarly qualified persons in order to avoid a hazard.
29. **DO NOT** use this heater with a programmer, timer, separate remote control system or any other device that switches the heater on automatically, since a fire risk exists if the heater is covered or positioned incorrectly.

---

## GENERAL PRECAUTIONS

---

Even though this heater operates very close to 100 percent combustion efficiency, it still produces small amounts of carbon monoxide.

- Carbon Monoxide (CO) is toxic.
- Pregnant women, persons with a heart or lung condition, anaemia or under the influence of alcohol, or those at high altitude, are more likely to be effected by Carbon Monoxide.
- CO can build up in a confined space and failure to provide adequate ventilation can be fatal.

The early symptoms of asphyxiation caused by inadequate ventilation are:

- headache
- nausea
- dizziness
- dry mouth or sore throat

Should anyone show these symptoms, they must **GET FRESH AIR IMMEDIATELY**. Turn off the heater and have it serviced before using again.

Be sure to follow all warnings in this manual.

## WE RECOMMEND THE USE OF A CARBON MONOXIDE DETECTOR

### BYSTANDERS

When the heater is to be operated in the presence of other people the user is responsible for informing those present of the safety precautions and of the hazards involved.

# ELECTRICAL CONNECTIONS



**WARNING: READ THESE ELECTRICAL SAFETY INSTRUCTIONS THOROUGHLY BEFORE CONNECTING THE PRODUCT TO THE MAINS SUPPLY.**

Connect the mains lead to a standard, 230 Volt (50Hz) electrical supply through an approved BS1363/A plug fitted with a BS1362 13 amp fuse.

If the plug has to be changed because of damage, it must be removed and a replacement fitted, following the wiring instructions shown below. The old plug must be discarded safely, as insertion into a power socket could cause an electrical hazard.



**WARNING: WIRES IN THE MAINS LEAD ARE COLOURED IN ACCORDANCE WITH THE FOLLOWING CODE: GREEN/YELLOW = EARTH, BLUE = NEUTRAL, BROWN = LIVE.**

- The BLUE wire must be connected to the terminal which is marked N or coloured black.
- The BROWN wire must be connected to the terminal which is marked L or coloured red.
- The YELLOW AND GREEN wire must be connected to the terminal which is marked E or  $\perp$  or coloured green.

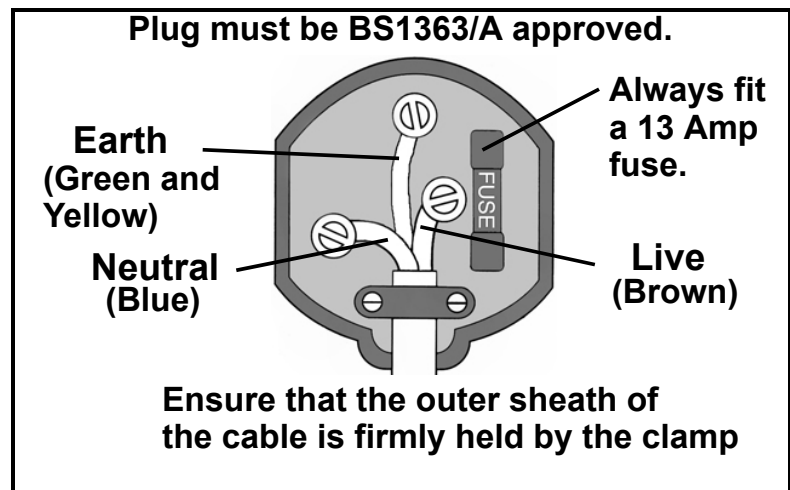

**We strongly recommend that this machine is connected to the mains supply through a Residual Current Device (RCD)**

**If you are not sure, consult a qualified electrician. DO NOT try to do any repairs.**

---

# PREPARATION

---

## UNPACKING

1. Remove heater from carton.
2. Remove all protective material which may have been applied to the heater for shipment.

## FUELS

Diesel or paraffin are the only fuels that should be used in this heater.

## FILLING THE FUEL TANK

**IMPORTANT:** Before filling the fuel tank the first time or after extended storage periods, drain the fuel tank of any moisture or condensation.

1. Follow all of the "Safety Precautions".
2. Remove the fuel cap.

**NOTE:** If you lose the fuel cap a replacement must be obtained before use, this is available from your local Clarke service department part number GF0K070000.

3. Fill the fuel tank with clean diesel or paraffin.

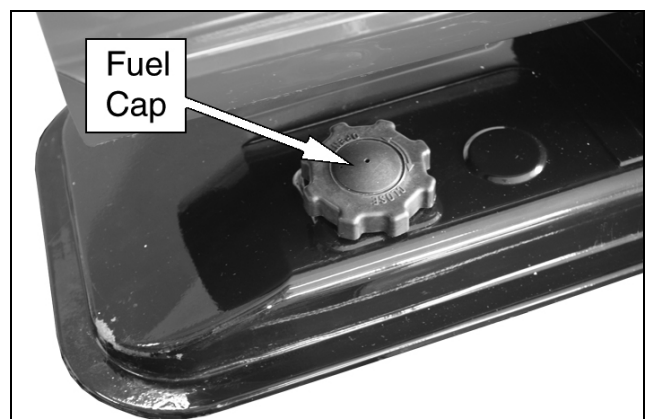

- In cold weather, condensation may develop in the tank if the tank is empty and it is recommended that a tablespoon of de-icer be added for each gallon of fuel in the tank.
- When filling the heater, make sure that the heater is level and do not overfill. Use a funnel or can with a long fill spout.
- Fill with a minimum of 5 litres of fuel.

## LOCATION

- Locate heater at a safe distance from combustible materials.
- This heater must not be placed on wooden floors or other combustible materials.
- When used, the heater should rest on suitable insulating material at least 1 inch thick and extending 3 ft. or more beyond the heater in all directions?
- Only operate on a flat level and stable surface.

---

# OPERATING INSTRUCTIONS

---

## HEATER START UP

---



**WARNING: DO NOT START HEATER WHEN EXCESS FUEL HAS ACCUMULATED IN THE COMBUSTION CHAMBER.**

1. Make sure power switch is in the OFF position.
2. Turn thermostat to lowest setting.
3. Plug the heater into the mains power supply.
4. Turn the thermostat to highest setting.
5. Start heater by setting the power switch to the ON position.

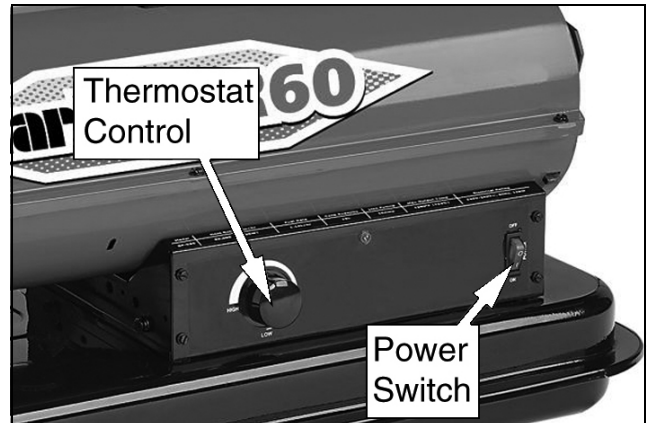

- The switch illuminates in the ON position.

6. Adjust thermostat to desired setting.

**NOTE:** Heater will cycle on/off to maintain an even temperature.

## HEATER SHUT DOWN

1. Set the power switch to the OFF position.
2. For extended shutdown, unplug the heater from the mains supply.

### BEFORE STORAGE

- Clean the heater as described in the MAINTENANCE section.
- We recommend completely filling the tank with fuel for extended storage to minimize condensation inside the tank.

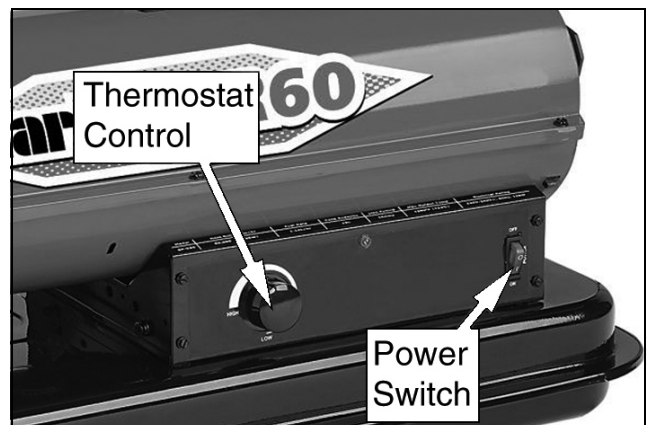



---

# MAINTENANCE, STORAGE AND SERVICING

---



**WARNING: TO PREVENT PERSONAL INJURY, UNPLUG THE HEATER FROM THE MAINS SUPPLY BEFORE SERVICING.**

---

## DAILY SCHEDULE

### GENERAL

1. Make a general visual inspection of the heater for loose or damaged parts.
2. Check nuts and bolts are secure.
3. Damaged parts should be repaired or replaced before using the heater again.
4. Check heater operation to be sure it is operating normally as follows:
  - The flame is contained within the heater.
  - The flame is essentially yellow.
  - There is no strong disagreeable odor, eye burning or other physical discomfort.
  - There is no smoke or soot internal or external to the heater.
  - There are no unplanned or unexplained shut downs of the heater

### REMOVE DUST

Clean the heater twice a season (more often under dusty conditions).

1. Remove accumulated dust from the transformer, burner, motor and fan blades with compressed air.
2. Wipe clean with a clean dry cloth.

### FUEL TANK (EVERY 500 HOURS)

Clean twice a season (during frequently used periods, clean twice a month). Drain and flush the fuel tank with clean fuel oil.

## FILTERS

Dirty air filters will cause an imbalance in the air-fuel mixture. The best indication that this condition exists is an increase in odour or difficulty getting your heater to ignite. This heater should never be operated without the filters in place. If required, clean the filters as follows.

### ACCESSING THE FILTERS

1. Make sure that the plug is removed from the mains supply before carrying out any maintenance.
2. Remove the six screws shown and remove the top cover of the heater.

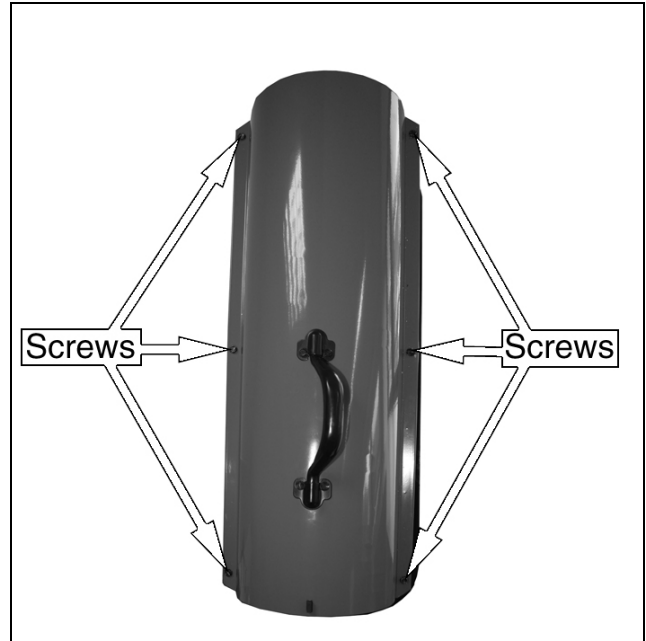

3. Lift out the rear guard.

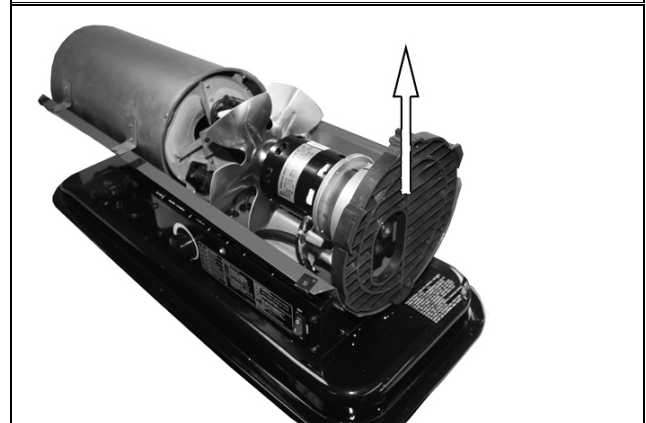

4. Remove the three screws securing the filter cover.
5. Pull the filter cover away from the motor.

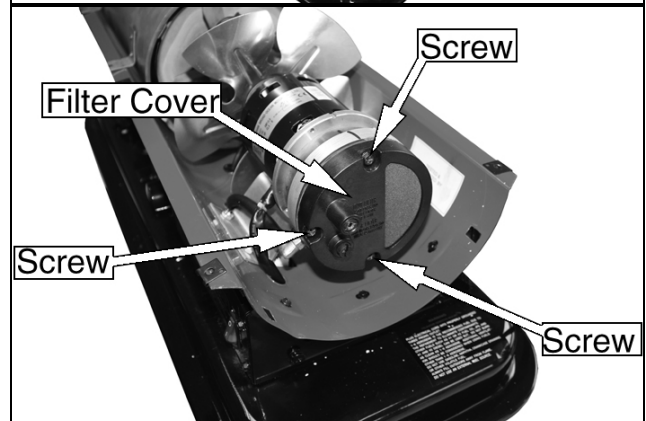

## AIR INTAKE FILTER CLEANING

1. To clean the air intake filter.
  - Remove and wash the filter element with a mild detergent.
  - Dry thoroughly and refit.
  - Clean as often as necessary (at least approximately every 500hrs.).
  - Do not oil the filter element. If your heater is used where there is considerable dust or dirt.

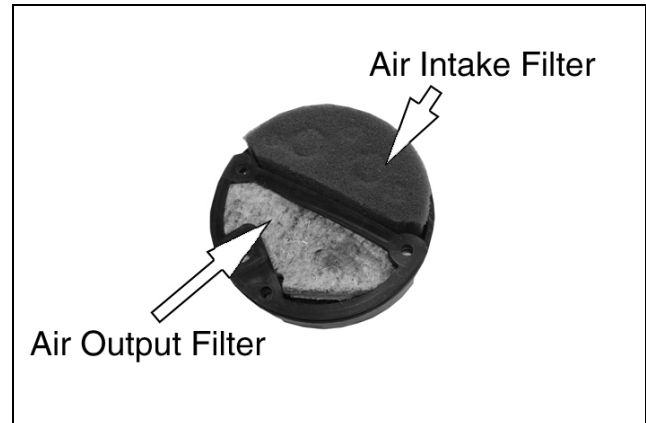

**NOTE:** If the filter is damaged or extremely dirty, a replacement filter of the same type must be fitted, this is available from your local Clarke service department part number GF50K100406.

## AIR OUTPUT FILTER CLEANING

1. To clean the air output filter (Annually or as required)
  - Remove the air output filter and tap the contaminated side gently on a solid object to remove contaminates.

**NOTE:** Compressed air or liquids should not be used to clean this filter.

**NOTE:** If the filter appears damaged or extremely dirty, replace it with a new filter of the same type must be obtained and fitted this is available from your local Clarke service department part number GF50K100401.

2. Reinstall clean filter in to the filter body in the same position as it was when removed.
3. Replace the filter cover and secure using the screws removed in step 4.

**NOTE:** When replacing the filter cover, make sure that the gasket is firmly in place and the screws in the filter cover are tight to prevent air leaks. if the gasket is damaged a replacement must be obtained and fitted this is available from your local Clarke service department part number GF50K100407.

4. Refit the rear guard and replace the top cover.
5. Make sure all screws are replaced before use.

## STORAGE

Store the heater in a dry location free from fumes or dust.

## TROUBLE SHOOTING

LED	OPERATION	TROUBLE SHOOTING
Steady ON	System Check	System performing self test. No action required.
Steady OFF		No action required.
2 Flashes	No flame detected	Heater fails to start. 1. Check fuel level 2. Return to Clarke service department for repair.
3 Flashes	High limit switch failure (unit has over-heated)	Make sure heater is cooled down, 1. Make sure that the power switch is set to the OFF position. 2. Wait 5 minutes 3. Start heater by setting the power switch to the ON position.
4 Flashes	Flame sensor failure	1. Return to Clarke service department for repair.

# WIRING DIAGRAM

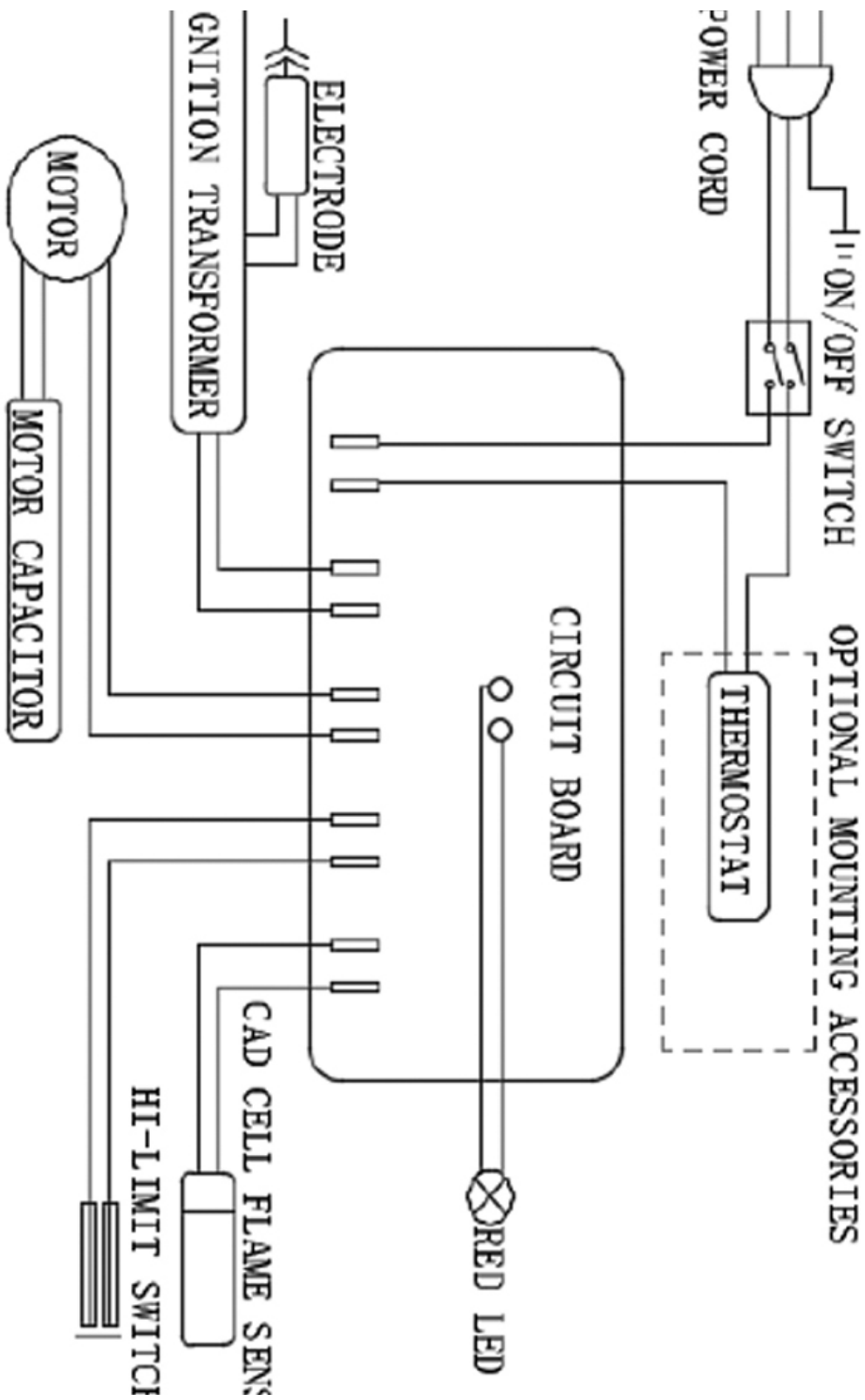

---

## SPECIFICATIONS

---

Model	XR60
Burn Rate: (Btu/hr.)	50,000
Fuel consumption:	1.6 L/hr.
Approx Running Time:	9.4 hr
Electrical input:	230V~50Hz
Power	166 W
Max.Outlet Temp:	1300°F (704°C)
Fuel Tank Capacity:	15 L
Ignition system:	Electric Ignition
Primary Safety Control:	Flame failure device
Weight (kg)	12.45
Dimensions (DxWxH) mm	774 x 300 x 388

---

## ENVIRONMENTAL RECYCLING POLICY

---



Through purchase of this product, the customer is taking on the obligation to deal with the WEEE in accordance with the WEEE regulations in relation to the treatment, recycling & recovery and environmentally sound disposal of the WEEE.

In effect, this means that this product must not be disposed of with general household waste. It must be disposed of according to the laws governing Waste Electrical and Electronic Equipment (WEEE) at a recognised disposal facility.

# DECLARATION OF CONFORMITY



Hemnal Street, Epping, Essex CM16 4LG

## DECLARATION OF CONFORMITY

This is an important document and should be retained.

We hereby declare that this product(s) complies with the following statutory requirement(s):

*Electromagnetic Compatibility Regulations 2016*  
*Electrical Equipment (Safety) Regulations 2016*  
*The Restriction of the Use of Certain Hazardous Substances in Electrical and Electronic Equipment Regulations 2012*

The following standards have been applied to the product(s):

EN 55014-1:2017+A11:2020, EN 55014-2:2015, EN 61000-3-2:2014, EN 61000-3-3:2013,  
EN 60335-2-102:2016, EN 60335-1:2012+A11:2014+A13:2017+A1:2019+A2:2019+A14:2019,  
IEC 62321-3-1:2013, IEC 62321-5:2013, IEC 62321-4:2013, IEC 62321-7-2:2017,  
IEC 62321-7-1:2015, IEC 62321-6:2015, IEC 62321-8:2017.

The technical documentation required to demonstrate that the product(s) meet(s) the requirement(s) of the aforementioned legislation has been compiled and is available for inspection by the relevant enforcement authorities.

The UKCA mark was first applied in: 2022

**Product Description:** Paraffin / Diesel Fired Space Heaters  
**Model number(s):** XR60, XR80, XR110, XR160, XR210  
**Serial / batch Number:** N/A  
**Date of issue:** 19/04/2022

Signed:

J.A. Clarke  
Director



Fitzwilliam Hall, Fitzwilliam Place, Dublin 2

## DECLARATION OF CONFORMITY

This is an important document and should be retained.

We hereby declare that this product(s) complies with the following directive(s):

2014/30/EU *Electromagnetic Compatibility Directive*  
2014/39/EU *Low Voltage Directive*  
2011/65/EU *Restriction of the Use of Certain Hazardous Substances in Electrical and Electronic Equipment Directive*

The following standards have been applied to the product(s):

EN 55014-1:2017+A11:2020, EN 55014-2:2015, EN 61000-3-2:2014, EN 61000-3-3:2013,  
EN 60335-2-102:2016, EN 60335-1:2012+A11:2014+A13:2017+A1:2019+A2:2019+A14:2019,  
IEC 62321-3-1:2013, IEC 62321-5:2013, IEC 62321-4:2013, IEC 62321-7-2:2017,  
IEC 62321-7-1:2015, IEC 62321-6:2015, IEC 62321-8:2017.

The technical documentation required to demonstrate that the product(s) meet(s) the requirement(s) of the aforementioned directive(s) has been compiled and is available for inspection by the relevant enforcement authorities.

The CE mark was first applied in: 2011

**Product Description:** Paraffin / Diesel Fired Space Heaters  
**Model number(s):** XR60, XR80, XR110, XR160, XR210  
**Serial / batch Number:** N/A  
**Date of issue:** 19/04/2022

Signed:

J.A. Clarke  
Director

# A SELECTION FROM THE VAST RANGE OF

# Clarke®

## QUALITY PRODUCTS



**AIR COMPRESSORS**  
From DIY to industrial, Plus air tools, spray guns and accessories.

**GENERATORS**  
Prime duty or emergency standby for business, home and leisure.

**POWER WASHERS**  
Hot and cold, electric and engine driven - we have what you need

**WELDERS**  
Mig, Arc, Tig and Spot. From DIY to auto/industrial.

**METALWORKING**  
Drills, grinders and saws for DIY and professional use.

**WOODWORKING**  
Saws, sanders, lathes, mortisers and dust extraction.

**HYDRAULICS**  
Cranes, body repair kits, transmission jacks for all types of workshop use.

**WATER PUMPS**  
Submersible, electric and engine driven for DIY, agriculture and industry.

**POWERTOOLS**  
Angle grinders, cordless drill sets, saws and sanders.

**STARTERS/CHARGERS**  
All sizes for car and commercial use.



## PARTS & SERVICE: 0208 988 7400

**Parts Enquiries**  
[Parts@clarkeinternational.com](mailto:Parts@clarkeinternational.com)

**Servicing & Technical Enquiries**  
[Service@clarkeinternational.com](mailto:Service@clarkeinternational.com)

SALES: UK 01992 565333 or Export 00 44 (0)1992 565335

**Clarke® INTERNATIONAL** Hemnall Street, Epping, Essex CM16 4LG  
[www.clarkeinternational.com](http://www.clarkeinternational.com)