

Clarke®

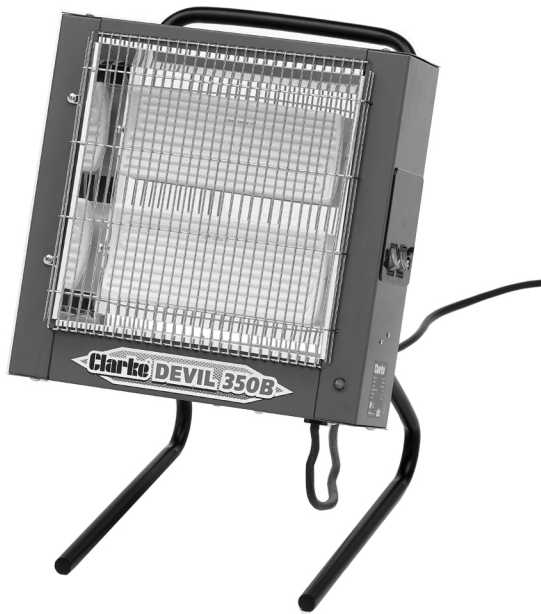

CERAMIC HEATER

MODEL NO: DEVIL 350B 230V/110V

PART NO: 6920330 & 6920332

OPERATING & MAINTENANCE INSTRUCTIONS



ORIGINAL INSTRUCTIONS

GC1218 - ISS 1

INTRODUCTION

Thank you for purchasing this CLARKE Ceramic Heater.

Before attempting to use this product, please read this manual thoroughly and follow the instructions carefully. In doing so you will ensure the safety of yourself and that of others around you, and you can look forward to your purchase giving you long and satisfactory service.

SPECIFICATIONS

Model Number	Devil 350B 230V	Devil 350B110V
Part Number	6920330	6920332
Weight	7.4 kg	7.7 kg
Dimensions (L x W x H)	385 x 395 x 580mm	
Rated input Current	10.5A	22A
Supply Voltage	230V/50 Hz	110V/50 Hz
Fuse Rating	13A	N/A
Insulation Class	IP20	
Max Heat Output	2400W (1200 per element)	

Please note that the details and specifications contained herein, are correct at the time of going to print. However, CLARKE International reserve the right to change specifications at any time without prior notice.

GUARANTEE

This product is guaranteed against faulty manufacture for a period of 12 months from the date of purchase. Please keep your receipt which will be required as proof of purchase.

This guarantee is invalid if the product is found to have been abused or tampered with in any way, or not used for the purpose for which it was intended.

Faulty goods should be returned to their place of purchase, no product can be returned to us without prior permission.

This guarantee does not effect your statutory rights.

GENERAL SAFETY RULES

Please keep these instructions in a safe place for future reference.

1. These heaters are for INDOOR USE ONLY in well insulated spaces.
2. Do not expose the heater or power cable to rain or wet conditions. Any water entering the heater will increase the risk of electric shock. DO NOT use this heater in a bathroom, shower room or any other wet environment.
3. NEVER locate the heater near combustible materials such as curtains, furniture etc. Allow at least 1 metre distance.
4. DO NOT locate the heater close to an adjacent wall or low ceiling. Allow a distance of at least 1 metre from a wall or ceiling. Avoid placing the heater directly below power socket outlets.
5. Take care to ensure that the wire guard cannot be covered.
6. Do not operate heater in explosive atmospheres such as in the presence of flammable liquids, gases or dust such as in a paint spray booth or any explosive environment.
7. Never stand the heater on a movable vehicle where it could tip over.
8. Do not allow the heating elements to become covered with dust which could become a fire hazard. If used in a dusty workplace it should be cleaned as described under Cleaning and Maintenance.
9. NEVER touch the heating elements for at least 15 minutes after switching off.
10. DO NOT leave the heater unattended.
11. If children are present always use with a fireguard.
12. Store the heater out of the reach of children and do not allow persons unfamiliar with these instructions to operate it.
13. This heater must only be located on a firm, level surface but is fitted with an anti-tilt switch which will turn the unit off if it should tip over.
14. Always disconnect the heater from the power supply before moving it.
15. Never leave the heater unattended while in use. Turn off at night if unattended.

ELECTRICAL SAFETY

1. Electrical appliances must match the power outlet. Never modify the plug in any way. Do not use adaptor plugs with earthed (grounded) appliances. Correct plugs and outlets will reduce the risk of electric shock.

2. Do not abuse the electrical cable. Never use the cable for pulling or unplugging the heater. Keep the cable away from sources of heat, oil, sharp edges or moving parts. Damaged or tangled cables increase the risk of electric shock.
3. Do not use this product with an extension cable.
4. ALWAYS disconnect from the power supply before moving the heater or performing any cleaning or maintenance tasks.
5. Keep the power cable well away from machines and ensure an adequate electrical supply is close at hand so that the operation is not restricted by the length of the cable.
6. Inspect the power cable regularly for signs of damage. DO NOT use if it is damaged and ALWAYS keep it away from the source of heat.
7. Check the heater for damage before use. Any damage should be properly repaired or the part replaced. If in doubt, **DO NOT** use. Consult your local Clarke dealer.

SERVICE & REPAIRS

1. If necessary, have your heater repaired by a qualified person using identical replacement parts. This will ensure that the safety of the appliance is maintained.

ENVIRONMENTAL RECYCLING POLICY



Through purchase of this product, the customer is taking on the obligation to deal with the WEEE in accordance with the WEEE regulations in relation to the treatment, recycling & recovery and environmentally sound disposal of the WEEE.

In effect, this means that this product must not be disposed of with general household waste. It must be disposed of according to the laws governing Waste Electrical and Electronic Equipment (WEEE) at a recognised disposal facility.

ELECTRICAL CONNECTIONS

DEVIL 350B (230V) UNITS



WARNING: READ THESE ELECTRICAL SAFETY INSTRUCTIONS THOROUGHLY BEFORE CONNECTING THE PRODUCT TO THE POWER SUPPLY.

The 230v model is provided with a 13 amp BS 1363 plug, fitted with a 13amp fuse and MUST be connected to a standard, 230 Volt (50Hz) electrical supply, preferably through a suitably fused isolator switch.

If the plug has to be changed because it is not suitable for your socket or because of damage, it must be removed and a replacement fitted, following the wiring instructions shown below. The old plug must be discarded safely as insertion into a power socket could cause an electrical hazard.



**WARNING: THE WIRES IN THE POWER CABLE OF THIS PRODUCT ARE COLOURED IN ACCORDANCE WITH THE FOLLOWING CODE:
BLUE = NEUTRAL BROWN = LIVE YELLOW AND GREEN = EARTH.**

The wires in the mains lead should be wired up in accordance with the following colour code:

- Connect the GREEN & YELLOW wire to the plug terminal marked with a letter E or
- Connect the BROWN wire to the plug terminal marked a letter "L".
- Connect the BLUE wire to the plug terminal marked a letter "N".

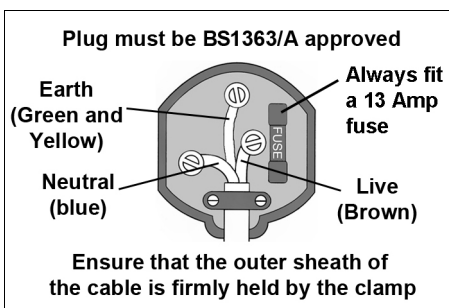

The fuse in the plug must be replaced with one of the same rating and this replacement must be ASTA approved to BS1362.

We strongly recommend that this machine is connected to the mains supply via a Residual Current Device (RCD).

DEVIL 350B (110V) UNITS

The 110V model is fitted with a 32 amp, three pin industrial plug to EN 60309 and MUST be connected to a 110 volt, 1 phase 50 Hz supply through a suitably

fused isolator switch. On no account must a 230V, 13 amp (BS1363) plug be used.

NOTE: *If a portable 110V transformer is used, make sure it has a rated capacity sufficient to take the load of the heater.*

If the heater is hard wired into the electrical system, all work must be carried out in accordance with IEE regulations.

If in any doubt, consult a qualified electrician. DO NOT attempt any electrical repairs yourself.

UNPACKING AND ASSEMBLY

Before assembling, please check contents against the following list and advise your dealer immediately if any parts are missing.

- 1 x Heater
- 2 x Legs
- 1 x Handle
- 1 x Remote Controller (batteries not included)
- 1 x Set fixings (screwed into back of the heater)



CAUTION: TAKE CARE TO REMOVE ALL PACKAGING MATERIALS FROM WITHIN THE FRONT OF THE HEATER. YOU WILL NEED TO RELEASE THE SCREWS SECURING THE FRONT GRILLE IN ORDER TO DO THIS.

-
1. Remove the 4 lower screws from the heater and use them to attach the legs as shown.
 2. Repeat with the two remaining screws to fit the handle as shown.
 3. DO NOT use the heater without fitting the legs.

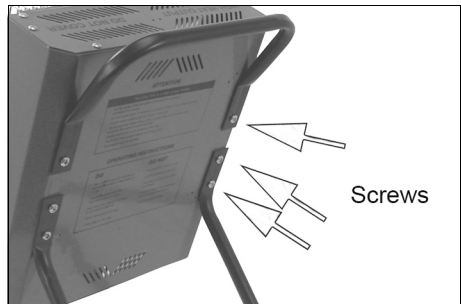

OPERATION



WARNING: FOR SAFE OPERATION OF THIS HEATER IT IS ESSENTIAL TO READ THESE INSTRUCTIONS BEFORE USE.

WARNING: PLEASE NOTE THAT THE HEATING ELEMENTS OF THIS PRODUCT DO NOT GLOW WHILST IN OPERATION. ANY PICTURES SHOWING THIS IN ADVERTISING MATERIAL ARE FOR ILLUSTRATION ONLY.

USING THE REMOTE CONTROL

All operations must be done using the remote control.

- 2 x AAA batteries are required and are installed as shown by the diagram found inside the control unit.
- The remote control must be directed at the heater display panel. It has a range of approx 2.5 metres and must be aimed at the correct angle.



MANUAL OPERATION

1. Stand the heater on a firm, level surface and following all safety precautions, connect to a suitable power supply.
 - The heater is equipped with an anti-tilt switch that automatically cuts the power off should the heater tip over. If this happens, stand the heater upright and it will immediately re-set.
2. Switch on the power at the primary switch.
 - The neon indicator will illuminate.

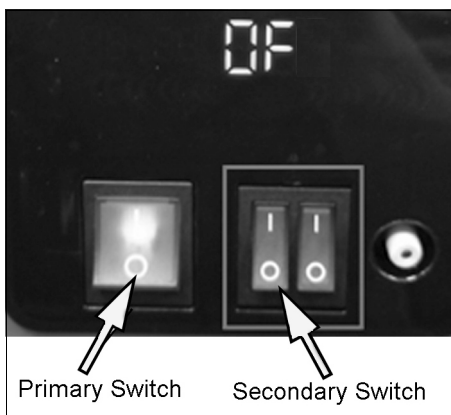

3. Set one or both secondary switches to the I (On) position as required.
 - The left one controls the upper heating element and the right one controls the lower.

4. Press the ON/OFF button on the remote control to switch the elements on.

- The secondary switches will each illuminate to show that the heating element is in use.
- The ambient room temperature will be displayed.

5. Set the target temperature by pressing the + and - arrow keys on the remote control to a value between 15°C and 45°C.



- During normal operation the bar below the temperature display pulsates to indicate that the heater is operating.
- When the heater has reached the target room temperature, the bar will become solid and the heater will automatically turn off. It will resume working when the ambient temperature falls 2°C below the target temperature.

PROGRAMMING THE TIMER

When programming, note that the selection will only remain actively displayed for approximately 10 seconds before reverting to the beginning of the process. If unsure what value you wish to enter, you can maintain the display by making constant adjustments with the +/- buttons until making your final selection.

SETTING CURRENT TIME

1. Switch the heater on with the remote control (on/off). The heating elements can be either on or off.
2. Press the TIME button.
 - SUN will flash repeatedly.
3. Use the left and right arrow buttons to choose a day.
4. Press the TIME button to go to the next step.
 - The first 2 digits (HOUR) of the time display will flash.
5. Use the + and - buttons to scroll to the correct time (24 hr clock).
6. Press the TIME button to set the Minutes.
7. Use the + and - buttons to scroll to the minutes you require.
8. Press the TIME button to finish the time and day set up.
 - The current time and day will show as a constant when the WEEK TIMER is activated.

NOTE: The Time and Day setting will be lost and will need to be reset. Once the heater is powered off completely, (either from the power switch or wall supply) Follow steps 1 to 8 to reset the clock.

THE WEEK TIMER

- The Week Timer covers a 7 day week (Monday to Sunday). You can program up to 3 individual "on/off" cycles each day.
- Each heating period can be set for a maximum of 24 hours in 10 minute increments. It is not possible for the program to span two consecutive days e.g. Monday 10pm to Tuesday 2am. If the user requires the heater to operate over the midnight period they would have to set two programs, one for Monday and one for Tuesday.
- The user can then also set two further programs for Tuesday if required.

- Always ensure that the heating elements are switched to the ON position when in Timer mode.

SETTING THE WEEK TIMER

SETTING THE DAY AND PROGRAM

1. Press the WEEK TIMER button on the remote control.
 - Monday will start to flash.
2. Press the left and right arrow keys to select the day you want your program to start and press the WEEK TIMER button to confirm.
 - Program 1 (01) will now flash.
3. Use the + and - buttons to select the program you want to set and press the WEEK TIMER button to confirm.
 - The programs will be displayed as 01, 02 and 03.
 - The first two digits of the clock will flash and the word ON will be displayed.
4. Use the + and - arrow keys to select the starting hour and press the WEEK TIMER button to confirm.
 - The second set of digits will flash.
5. Use the + and - arrow keys to select the starting minutes and press the WEEK TIMER button to confirm.
 - The display will show OF and the first two digits of the clock will flash. You can now set the time the heater will turn off.
6. Use the + and - arrow keys to select the finishing hour and press the WEEK TIMER button to confirm.
 - The second set of digits will flash.
7. Use the + and - arrow keys to select the finishing minutes (in increment of 10) and press the WEEK TIMER button to confirm.

SETTING FURTHER PROGRAMS

1. Repeat the above steps to program each individual program/day.

ACTIVATING THE TIMER FUNCTION

1. To activate the TIMER mode press the TIMER On/Off button.
 - The Day and Time will be shown on the display.
2. To turn the heater off press the TIMER On/Off button. The day and time will be removed from the display and only temperature will be shown.

TO CLEAR A PROGRAM

1. To clear a program press the WEEK TIMER button once scroll to the day that needs to be reset using the left and right arrows.
2. Press and hold the TIMER On/Off button for approximately 3 to 4 seconds.
 - A beep will be heard from the heater and the time for that program will show 00:00. The program is then ready to be set once again.

ECO MODE

Press the ECO button once to activate ECO mode.

- Only ambient room temperature will be displayed.
- Other lights on the display will switch off.

CLEANING & MAINTENANCE

Always allow the heater to cool down for at least 15 minutes and disconnect it from the mains supply before performing any maintenance tasks.

PERIODICALLY

1. Inspect the power cable for damage. Undue heat will cause the cable to stiffen and crack. If this is found, have the cable replaced. Check your cable routing and ensure it is well away from the heat source.
2. Should the heater become dirty, disconnect it from the power supply, remove the front guard and wipe the reflector and elements with a clean damp cloth. DO NOT use abrasive cleaners. Take care that no moisture enters the heater.
3. Refer to your CLARKE dealer if internal maintenance is required.
4. When storing the heater, allow it to cool down before storing it in a dry, well ventilated place.

ELEMENT REPLACEMENT

Ceramic heating elements are long lasting and should not need replacing under normal circumstances. Should this become necessary take the heater to your Clarke dealer.

FAULT FINDING

SYMPTOM	PROBLEM	SOLUTION
Heater does not operate, although plugged in and switched on.	Plug is loose/bad connection.	Remove the plug & check the connection of the plug and socket.
	Fuse blown.	Replace if necessary and investigate the cause. If the fuse blows repeatedly, consult your Clarke dealer.
	No power at socket outlet.	Insert the plug into a suitable socket.
	Tilt safety switch is disabling the heater.	Ensure heater is upright. If the switch does not re-set, consult your Clarke dealer.
Heater does not respond to remote controller	Batteries defective.	Replace batteries.
	Controller is out of range or not pointing at the display panel.	Move closer or try different angles of pointing the controller at the heater.

PARTS DIAGRAM

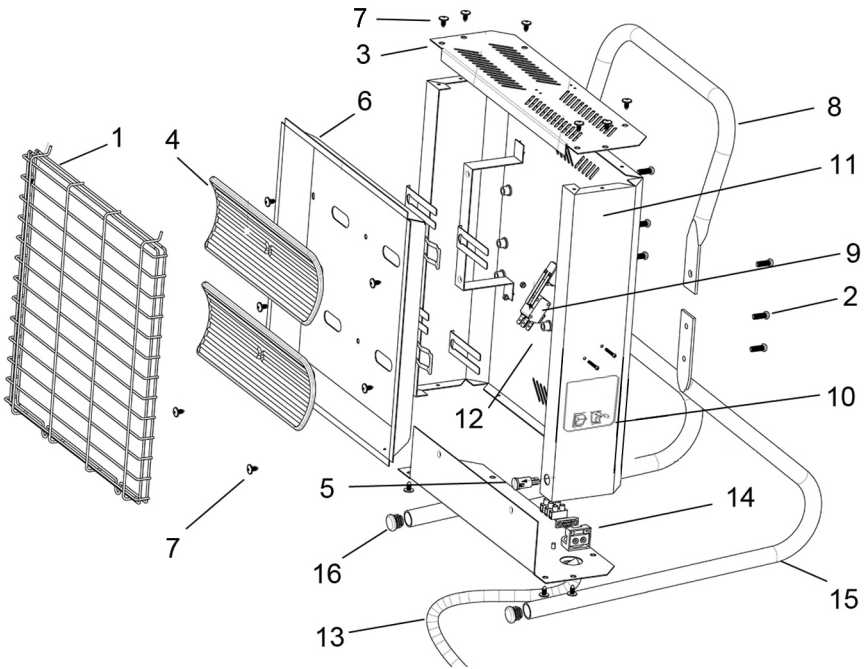

No	Description
1	Front Guard
2	M6x15 Pan Head Screw
3	Top Panel
4	Ceramic Heat Element
5	Neon Indicator Lamp
6	Reflector Panel
7	No10 x12 Pan Screw
8	Handle

No	Description
9	Tip-Over Switch
10	Switch Assembly
11	Casing
12	Screw
13	Power Cable & Plug
14	Cable Clamp
15	Leg
16	End Plug
n/a	Remote Control Unit

A selection of suitable extension leads & plugs is available from your nearest CLARKE dealer, for further information, contact your nearest dealer, or telephone CLARKE International Sales department on 01992 565300.

DECLARATION OF CONFORMITY



Clarke[®]
INTERNATIONAL

Hemnall Street, Epping, Essex CM16 4LG

DECLARATION OF CONFORMITY

This is an important document and should be retained.

We hereby declare that this product(s) complies with the following directive(s):

2014/30/EU *Electromagnetic Compatibility Directive.*
2014/35/EU *Low Voltage Equipment Directive.*
2011/65/EU *Restriction of Hazardous substances.*
2009/125/EC *Eco- Design Directive (EU 2015/1188).*

The following standards have been applied to the product(s):

EN 60335-2-30:2009 +A11:2012, EN 60335-1:2012 +A11:2014, EN 55014-1:2017,
EN 55014-2:2015, EN 61000-3-2:2014, EN 61000-3-3:2013.

The technical documentation required to demonstrate that the product(s) meet(s) the requirement(s) of the aforementioned directive(s) has been compiled and is available for inspection by the relevant enforcement authorities.

The CE mark was first applied in: 2018

Product Description: Electric Ceramic Heater:
Model number(s): Devil 350B (2.4 kW / 230V), Devil 350B (2.4 kW/ 110V).
Serial / batch Number: N/A
Date of Issue: 30/11/2018

Signed:

J.A. Clarke
Director

A SELECTION FROM THE VAST RANGE OF

Clarke®

QUALITY PRODUCTS

AIR COMPRESSORS

From DIY to industrial, Plus air tools, spray guns and accessories.

GENERATORS

Prime duty or emergency standby for business, home and leisure.

POWER WASHERS

Hot and cold, electric and engine driven - we have what you need

WELDERS

Mig, Arc, Tig and Spot. From DIY to auto/industrial.

METALWORKING

Drills, grinders and saws for DIY and professional use.

WOODWORKING

Saws, sanders, lathes, mortisers and dust extraction.

HYDRAULICS

Cranes, body repair kits, transmission jacks for all types of workshop use.

WATER PUMPS

Submersible, electric and engine driven for DIY, agriculture and industry.

POWERTOOLS

Angle grinders, cordless drill sets, saws and sanders.

STARTERS/CHARGERS

All sizes for car and commercial use.



PARTS & SERVICE: 0208 988 7400

E-mail: Parts@clarkeinternational.com or Service@clarkeinternational.com

SALES: UK 01992 565333 or Export 00 44 (0)1992 565335

Clarke INTERNATIONAL Hemnall Street, Epping, Essex CM16 4LG
www.clarkeinternational.com